

---

# OM25

**PS/2**

**MCU+Sensor 2-in-1  
Optical Mouse IC**

## **Product Specification**

**DOC. VERSION 1.1**

---

# Contents

1	General Description .....	1
2	Features .....	1
3	Pin Configurations (Package) .....	2
4	Functional Block Diagram .....	3
5	Pin Description .....	3
6	Absolute Maximum Rating .....	4
7	Electrical Characteristics .....	4
8	Application Circuit .....	5
9	PCB Holes Map.....	6

## 1 General Description

OM25 is integrated with a PS/2 Micro-Controller Unit (MCU) for a computer optical mouse. It is housed in a 16 pins staggered Dual Inline Package (DIP) for 3D3K application. Resolution is 800 DPI. It catches the images of surfaces 3200 times per second. Tracking speed is up to 25 Inches Per Second (IPS).

## 2 Features

- Integrated optical sensor and PS/2 MCU into single chip.
- High speed motion detection up to 25 IPS.
- Navigates over a wide range of surface.
- Frame rate up to 3200 frames per second.
- 5 volt power supply.
- Built-in 3.3V Voltage Regulator.
- 16-pin staggered DIP.
- Support 3D3K and Z/2 scroller mouse.
- Two operating modes, Active and Standby modes.
- Automatic Standby mode (After no motion occurs more then 1 second).

### 3 Pin Configurations (Package)

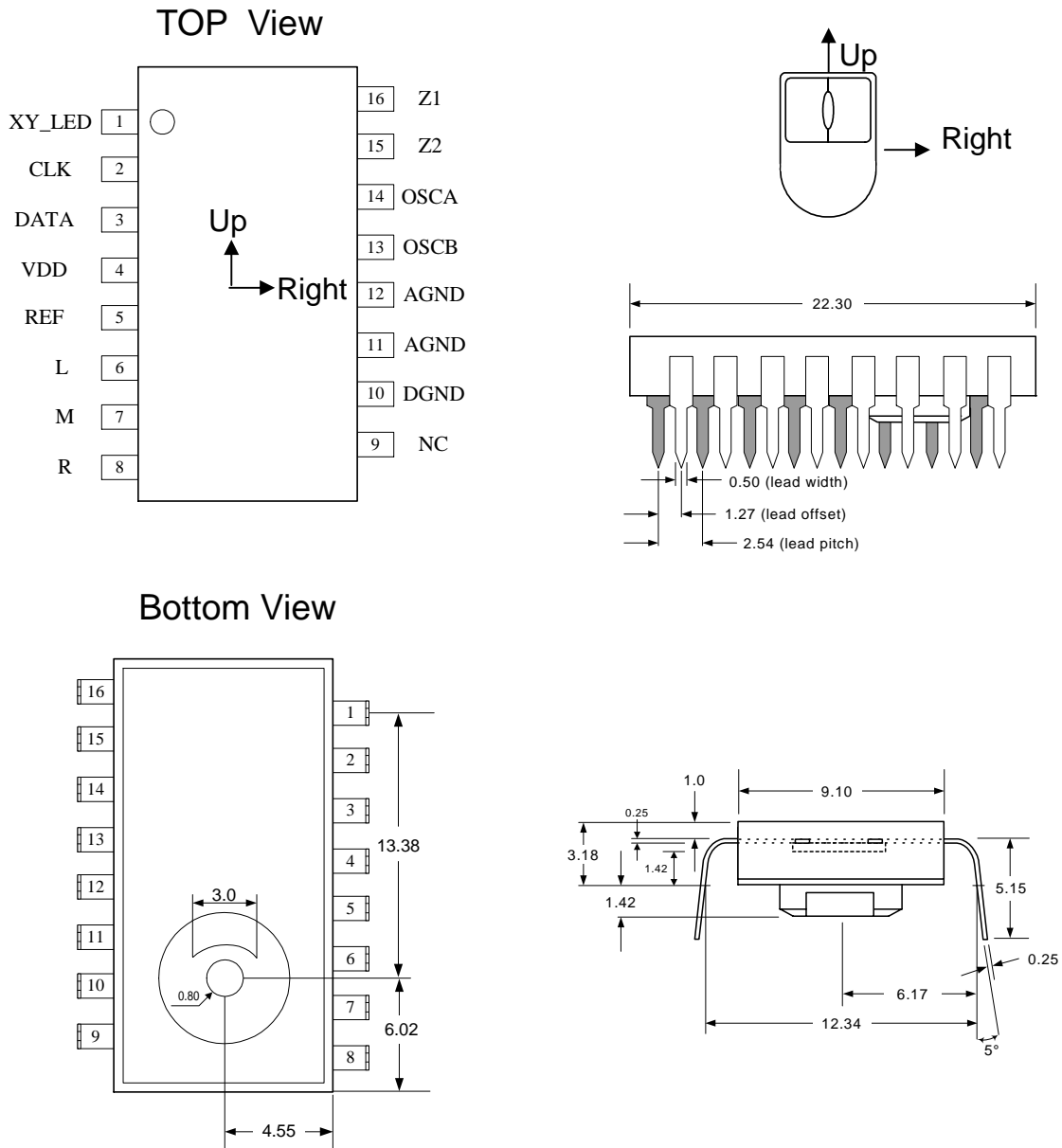

- NOTE**
- Dimension in millimeter.
  - Dimension tolerance is +/- 0.1 mm.
  - Coplanarity of leads is 0.1 mm.
  - Lead pitch tolerance is +/- 0.15 mm.
  - Cumulative pitch tolerance is +/- 0.15 mm.
  - Angular tolerance is +/- 3°.
  - Maximum flash is +0.2 mm.
  - Chamfer (25° X 2) on the taper side of the lead.

## 4 Functional Block Diagram

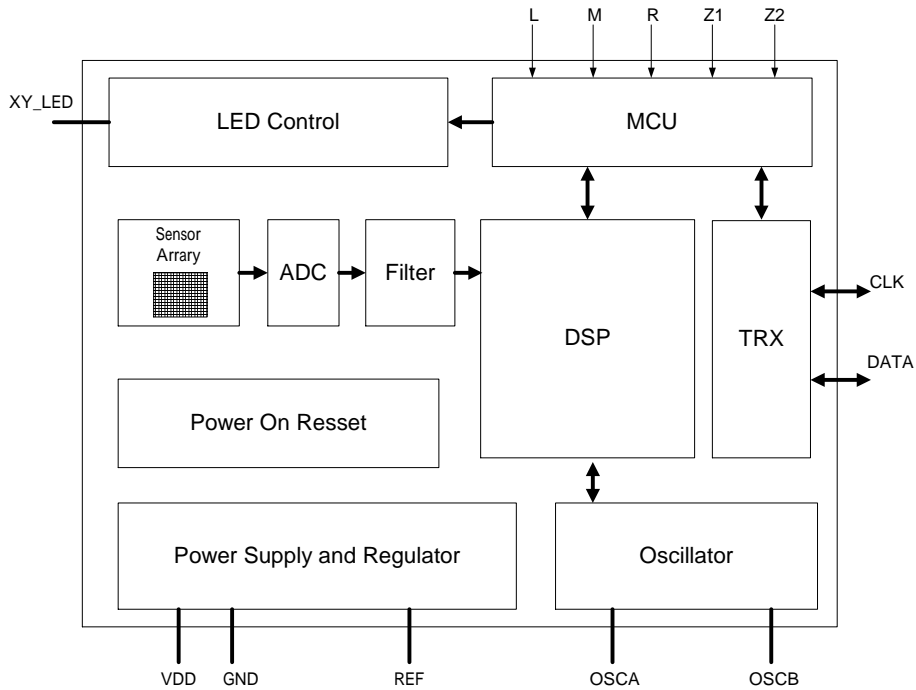

## 5 Pin Description

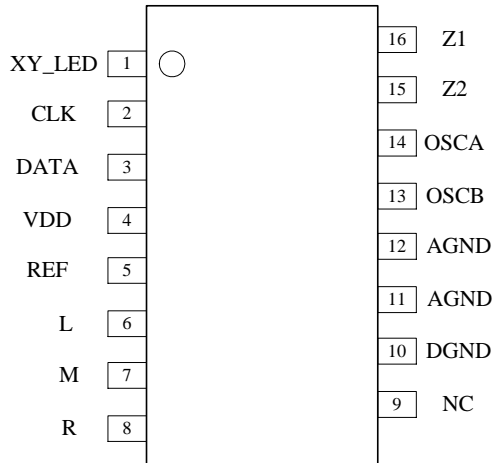

Pin No.	Symbol	I/O	Description
1	XY_LED	O	LED control
2	CLK	I/O	CLOCK
3	DATA	I/O	DATA
4	VDD	-	5 volt DC power supply
5	REF	-	3.3V Reference
6	L	I	Left key
7	M	I	Middle key
8	R	I	Right key
9	NC	-	NC
10	DGND	-	Digital Ground
11	AGND	-	Analog Ground
12	AGND	-	Analog Ground
13	OSCB	-	Oscillator
14	OSCA	-	
15	Z2	I	Scroller
16	Z1	I	

## 6 Absolute Maximum Rating

Parameter	Symbol	Min.	Max	Unit	Notes
Storage Temperature Range	TSTR	-40	85		
Operating Temperature Range	TOPR	0	40		
Lead solder Temperature	-	-	245		For 10 seconds, 1.6mm below seating plane.
Supply Voltage	VDD	4.5	5.5	V	
Reference Voltage	Vref	3.0	3.6	V	
ESD	-	-	2	KV	All pins, human body model
Input Voltage	-	-0.5	3.6	V	All GPIO except pin2, pin3

## 7 Electrical Characteristics

Parameter	Symbol	Min.	Typ.	Max	Unit	Notes	
Supply Voltage	VDD	4.5	5.0	5.5	V		
Input Voltage	-	-0.5	3.3	3.6	V		
Resolution	Res	-	800	-	DPI		
Speed	S	-	-	25	in/sec		
Acceleration	A	-	3.3	-	g		
Clock Frequency	FCLK	-	24	-	MHz		
Sensor Frame Rate	f <sub>frame</sub>	-	3200	-	frames/sec		
DC Supply Current	Mouse Active	IDDACT	-	25	-	mA	No load on GPIO. Excluding LED current.
	Standby	IDDSTB	-	24	-	mA	
LED Frame Rate	Mouse Active	-	3200	-	frames/sec	After no motion occurs more then 1 second	
	Standby	-	100	-	frames/sec		
LED Duty Cycle	Mouse Active	-	-	70%	-		
	Standby	-	-	12%	-		
Distance from Lens Reference Plane to Surface	D	-	2.2	2.4	mm		

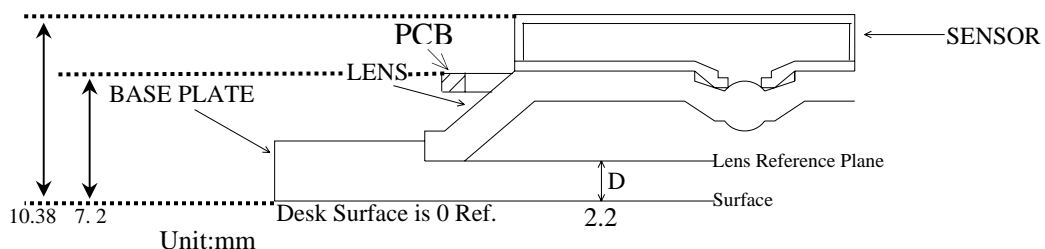

## 8 Application Circuit

**PS/2 Connector**

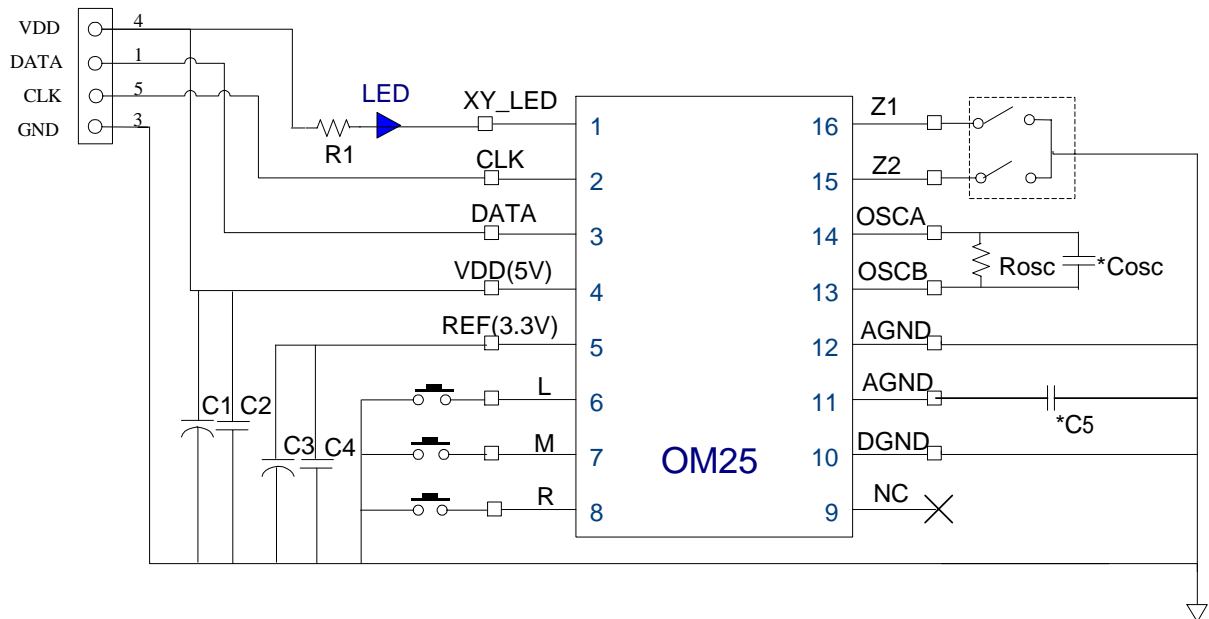
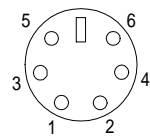

**R1 : 33~68Ω, C1 : 10uF, C2 : 0.1uF, C3 : 10uF, C4 : 0.1uF, R<sub>osc</sub> : 62KΩ,**

**\*C5 : short, \*C<sub>osc</sub> : 1nF**

**NOTE**

\* C5 : for future use

\*C<sub>osc</sub>: for EFT

## 9 PCB Holes Map

